



CONFIDENCE
AUTOMATION PVT. LTD.



Precision



CONFIDENCE

AUTOMATION PVT. LTD.

Established in the year 2009, we "Confidence Automation Pvt. Ltd.", (CAPL) are engaged in supplying CNC Machines, manufacturing, exporting a wide range of CNC Accessories, Cutting Tools, Computer Aided Design (CAD) and Computer Aided Manufacturing (CAM) Solutions. Under the offered the world's most reputed range, we provide Single Point Solution for CNC Machine Tool Industry.

The CAPL sales and service force ensures that you can identify the best technology solution for your needs. We also help ensure correct installation, operation, handling, servicing, training of your operators and providing spare parts and upgrades.

We supply a comprehensive range of high precision, high performance, high reliability products from the world's technology leaders to enhance your manufacturing productivity.

CAPL supplies the best products in the machine tools industry, enhancing your manufacturing productivity. Our reliable brands augment your advanced machining systems, CNCs and automated processes with further precision and efficiency, delivering optimal up-time.

Products include CNC Machines, Stabilizer, Compressor, Cutting Tools, Chucks, Special Chucks, vices, work holding systems, angle heads and VDI tooling. Tool up with the CAPL Single Point Solution which serves a wide range of specialized requirements, applications and specifications.

We have group of well experienced and qualified professionals having vast experience of 15 years in machine tools Industry. We understand compatibility with old and new concepts. CAPL is single point source for customer who is part of Machine tools Fraternity.

Under the supervision of our Promoter, 'Mr. Milan Goswami', we are able to fulfill the varied requirements of Customers. He is widely appreciated for his excellent leadership & business skills, in-depth industrial knowledge and ethical business policies.



New Machines

- Sliding Head Machine
- CNC Turning Center
- Vertical Machining Center (VMC)
- Horizontal Machining Center (HMC)
- Vertical Lathe (VTL)

Pre Owned Machines

- Choice is Yours

Accessories

Power ONN

- Servo Stabilizer
- Isolation Transformer
- U.P.S.

AIR Compressor

- Screw Type
- Reciprocating
- Air Dryer

Cutting Tools

- Cutting Tools
- Shrinkfit Unit
- Tool Presetter

CNC Chuck

- Power Chuck
- Collet Chuck
- Special Chuck

Work Holding

- Vise
- Fixture

CNC Accessories

- Angle Head
- Spindle Speeder
- CNC Probe
- Bar Feeder
- Bar Puller
- Steady Rest

CNC Software

- CAM Software
- Machine Monitoring Solution
- Virtual Machining Software

Manufacturing Component

- Turn Components
- Milling Components

CNC Services & Solution

- Machine Installation & Commissioning.
- Machine Calibration Services.
- Machine Maintenance Contract
- Automation & Inteference
- Project Devlopment

Precision Turning Center



High precision and productivity turning center slant high rigidity one piece bed structure with roller type LM guideway on all axes ensures stable travers, vibrational absorption and increased chip disposals.

Achieved high-precision machining by improving spindle heat displacement. Best Linear axes to prevent vibration and secure dynamic rigidity, so ensure precise machining and high productivity.

High Speed Vertical Machining Center



High speed and high accuracy machining center Space saving and long stroke

- Optimum for high-speed and high-efficiency machining of all workpiece size.
 - Super compact machine. Productivity improvement per space.
 - High speed tool change by double arm type ATC.
 - X, Y and Z axes high rapid traverse rate realizes the high speed machining.
-



CONFIDENCE
AUTOMATION PVT. LTD.

Vertical Turning Lathe



If you have minimal floor space but require serious machining, the PUMA V Series is your best. The integral box guideway bed design provides vibration free performance and ensures heavy duty and high precision cutting over long term operation.

Thanks to its rigid foundation and high power spindle, the PUMA V Series will easily handle long shifts filled with heavy duty cutting. and you can option a two-spindle model for bonus productivity.

CNC Takang Flat Bed Heavy Duty Lathes



CNC-TAKANG is one of the leading machine tools manufacturers in Taiwan. They have been in business since 1973. The company is efficiently organized with top engineers with more than 20 years of manufacturing experience.

CNC TAKANG are worldwide recognized for their FLAT BED HEAVY DUTY CNC LATHES

HARDINGE GROUP

MIKRON

HYUNDAI WIA

FPT

FANUC

HURCO

Sodick

FEMCO

Micromatic

LOKUMA

brother at your side

SIEMENS

TAKISAWA

Mazak

DOOSAN

EMAG

Kothari Group

FANUC

HONOR SEIKI CO., LTD. Yes! We Are HONOR!

Haruha Europe

CNC-TAKANG

AWEA

+GF+

Nakanura Time Precision Industry

MANFORD

LMW

MC MACHINERY SYSTEMS, INC.

VISION WIDE TECH CO., LTD.

SMEG SAMSUNG MACHINE TOOLS

DOOSAN

Matsuura

chiron

MITSUI SEIKI

MAKINO

BFW

CITIZEN

star

Hartford

TORNOS

KITAMURA

FLUJ MACHINERY CO., LTD.

DMG MORI



CONFIDENCE
AUTOMATION PVT. LTD.

Pre-owned CNC Machines

First choice for second hand CNC Machines

Whether you wish to buy or sell a used CNC machine, our staff in the TECH Center is at your service with help and advice.

We would like to help you buying our used machine on the best terms!!!
Then we're the right place for you: we take back your used machine at a fair market price or broker it to a partner we certify.

You're looking for a reliable, used CNC machine....???
Together we will find the right used machine for you.

Advantages with Us :

- Acceptance of used CNC machines at market prices
- Informing certified partners of used machines
- Worldwide free used machine exchange on the Internet
- Fair and independent determination of the machine's value
- Finding and selling appropriate used CNC machines

The Confidence Automation Pvt. Ltd. (CAPL) allows you to choose dependable CNC Machines and options that work best for your needs. Certified Pre-Owned machines come with a labor and parts warranty, offered at 20% to 40% less than their new machine counterpart. Used machines are fully serviced and functional, priced at 40% to 60% less than a new machine and each used machine comes with a 30-day parts warranty.

All taxes, freight, destination charges, rigging, setup and other shipping and handling costs are not included in this price. All prices are EXWORKS point of loading.

Power ONN



1. Servo Stabilizer



2. Isolation Transformer



3. U.P.S.

1. We Confidence Corporation offer a broad range of air - cooled and oil - cooled voltage stabilizers, ranging from from 1 KVA to 1000 KVA. We manufacture stabilizers of unbalanced type as well as balanced type.
2. We offer wide range of Ultra Isolation Transformer that have excellent protecting techniques. Our transformers are technically sound in every dimensions.
3. Our broad range of high-tech Online UPS is equipped with various user friendly services which ensure durability and optimum quality. These UPS play a vital role in varied industries, widely used for applications like tele-communication, medical activities, protecting computers, medical diagnostics, biomedical equipment and sensitive processing units. Provided with Dual LCD, these UPS are known for easy Monitoring.

AIR Compressor



1. Reciprocating



2. Screw Type



3. Air Dryer

1. Our TWO STAGE reciprocating compressor family has earned worldwide recognition for reliable, trustworthy performance that saves money and enhances business success through ability to thrive in punishing applications with lower cycle costs & configurations that meet varying needs.
2. Our Single Screw compressor family has covered 10KW to 350KW range are applicable in all industry to full fill customer needs. Quality is the only criterion to prove the technology with high efficiency, high reliability, reasonable structure & longer services life.
3. A compressed air dryer is a device for removing water vapor from compressed air. Compressed air dryers are commonly found in a wide range of industrial and commercial facilities.



CONFIDENCE
AUTOMATION PVT. LTD.

Cutting Tools



1. Cutting Tools



2. Shirkfit Unit



3. Tool Presetter

THE RIGHT TOOL AT THE RIGHT PLACE AT THE RIGHT TIME.

1. LMT Tool Systems is the international sales company in the LMT Group. Its sales and service centers and an alliance with specialized partners enable LMT Tool Systems to offer customers integrated tool packages on an industrial scale worldwide.
2. Power Shrink is the inductive shrink-clamping unit for HSS and carbide tools. It allows you considerably to reduce the setup times in your production facility with a highly accurate concentricity, long tool lives and reduced tooling costs.
3. The universal tool presetter and measuring machine has been designed specifically for measuring tools for manufacturing production. With us you can measure your tools quickly & easily with μ -precision and reliably. Simple to operate, equipped with all the standard measuring functions at an attractive price.

CNC Chuck

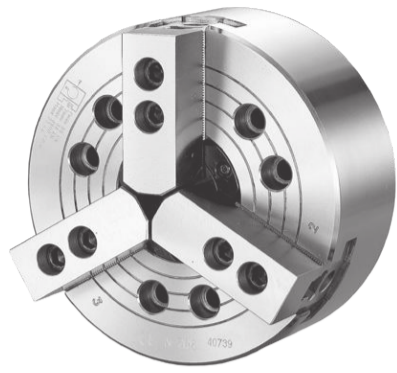

1. Power Chuck



2. Collet Chuck



3. Special Chuck

1. The series of power chucks are wide-ranging and so technologically advanced that we can offer solutions for all machining conditions, no matter how punishing. Our unique innovations in work holding solutions, supported by highly specialized design teams and a proven history of excellence, show our capacity to challenge the world of engineering.
2. Collet Chucks are of course an integral part of the machining process when looking to produce the highest quality components, delivering numerous benefits like quick chucking, self-centering, high clamping force & precise centering reducing runoff.
3. We realize that the demands of each application can vary widely and offer a range of Special Chucks to meet our customers' requirements whether they are looking for a time efficient Quick Change Chuck or the supreme accuracy and compact design offered by a Special Chuck.

Work Holding

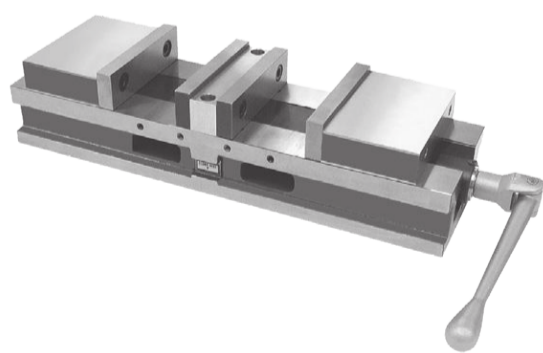

1. Vise

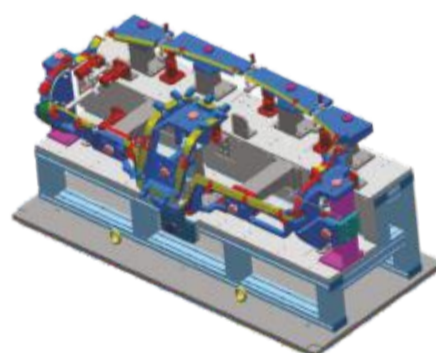

2. Fixture

1. THE BEST VISES! AND THE MOST COMPLETE FOR SINGLE, DOUBLE AND SELF-CENTERING CLAMPING.
Born to be installed on machining centers, FMS series of vises allow work holding with perfect alignment in a space saving design, extremely high wear resistance, deflection reduced 2 times with respect to the STD modular vises (base thickness is doubled), possibility to clamp more pieces simultaneously with mechanical, hydraulic, pneumatic or electric devices. You can use them both for vertical and horizontal clamping without any price charge
2. We are reputed supplier of the Fixture. A "SMART" fixture will minimize the chance for human error and decrease your dependence on the machine operator to provide quality parts. Your work holding must eliminate the possibility for operator miss-loads.



CONFIDENCE
AUTOMATION PVT. LTD.

CNC Accessories



Angle Head



Spindle Speeder



CNC Probe



Bar Feeder

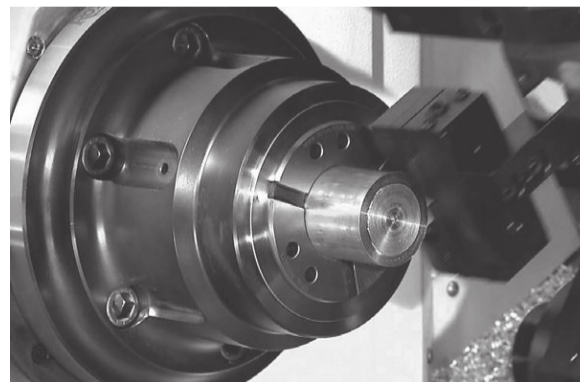

Bar Puller



Steady Rest

Our team's great experience in the world of the machine tool, has allowed us to be capable of creating an incalculable number of applications for each customer satisfying the most specific needs of each sector.

We are specialists in CNC accessories for the majority of the machines existing into the market, from the classic ones to the latest models. Our standard products range assures increasing ratios, smooth and quiet running, very high output per tool, no maintenance and increases tool and machine life.

CNC Software



1. CAM Software

2. Machine Monitoring Solution

3. Virtual Machining Software

1. We are doing consulting for CNC software for turning and milling machines. We provide a full solution with the use of the most advanced technology available to speed up productivity and shorten delivery times.
2. Monitoring means increased quality and lowered costs. Basically a monitoring solution will make sure that a tool is present and a process is running within its correct parameters.
3. A virtual machine can support individual processes or a complete system depending on the abstraction level where virtualization occurs. Some VMs support flexible hardware usage and software isolation, while others translate from one instruction set to another.

Manufacturing Component



Turn Component



Milling Component

We offers a wide range of Component for producing precision detailed functional parts ready for use in a variety of applications. We use the latest removal and subtractive production systems quickly and cost effectively to meet all your production needs.

Our Technologies

- CNC Machining Technology
- Investment Die Casting
- Forging
- Casting
- Pressure Die Casting
- Rapid Proto Type (RPT)



CONFIDENCE
AUTOMATION PVT. LTD.

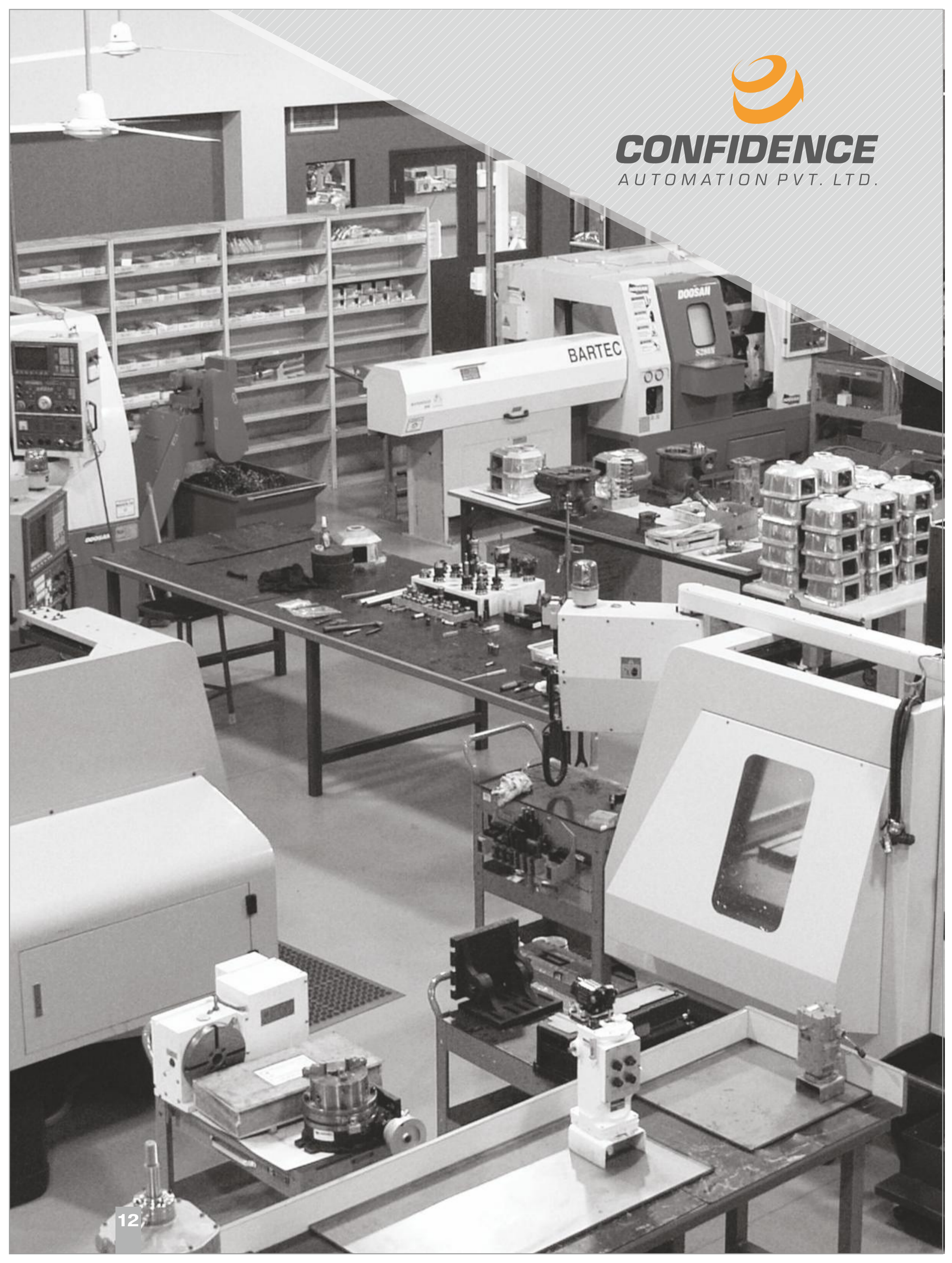

CNC Services & Solution

OUR vision to achieve excellence in providing SINGLE POINT SOLUTIONS to CNC machine users and for improving the productivity of CNC Machines.

- Machine Installation & Commissioning.
- Machine Calibration Services
BALL BAR TESTING
LASER CALIBRATION.
- Machine Maintenance Contract
MECHANICAL
ELECTRICAL
- Automation & Inteference
- Project Devlopment

We do take up automation & system integration projects. We have a vast experience in executing various types of automation projects for Machine tools industries.

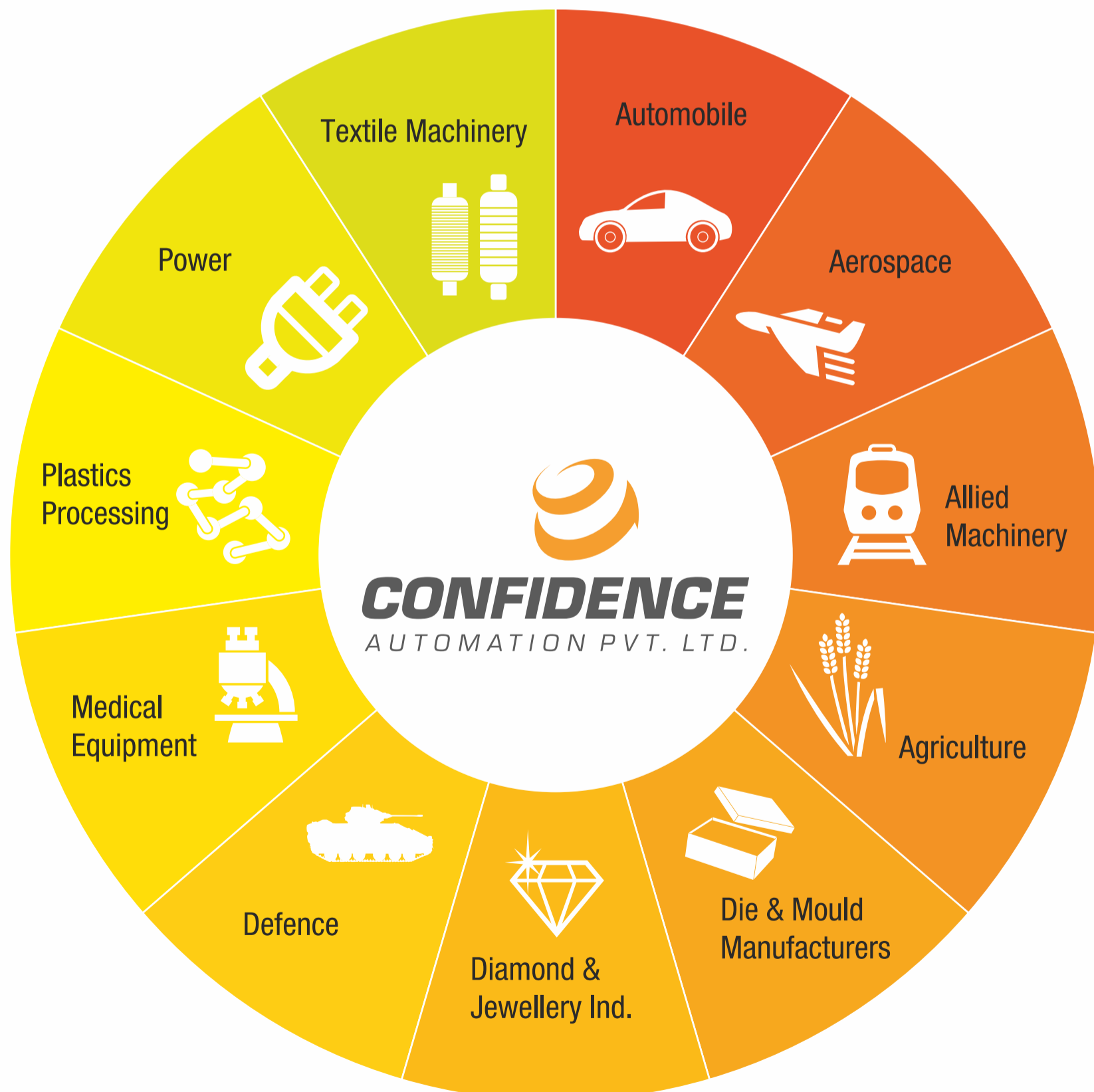



CONFIDENCE
AUTOMATION PVT. LTD.

Tech Center

Our activities in Gujarat since Jan 15, 2009, CONFIDENCE Automation Pvt. Ltd. (CAPL) plan to expand its presence in the fast growing Indian market investing in a new technology centre with a large showroom.

This technology centre is spread across an area of 3,500 sq ft. and is located in the industrial area of metoda GIDC, Rajkot. The CAPL is responsible for the complete service and support of the entire product portfolios of all manufacturers who are engaged with company.

This technology centre is an utmost necessity in a competitive machine tool market like India. The tech centre is equipped with a showroom where products from all CAPL suppliers would be displayed. Up to 12 machines from world reputed products range would be displayed at the center. Live cutting demonstrations in the form of workshops, seminars and trainings would also take place here.

The first concern of a customer before buying a machine is to see the machine and the way it functions. This would be addressed by the tech centre as the customer will now be able to check a variety of machines in the CAPL product range and also make test cuts before even placing an order for the machine.

The tech centre will also have the facility to conduct technical training to customers which will help them in operating the machines and understanding them better.

The tech centre will be equipped with a warehouse to store spare parts which will ensure speedy replacements of machine spare parts and a warehouse of PRE OWNED machines.

The main objective of application support is to provide the customer with a total competitive solution. With the new Tech Center facility in place, this objective would be achieved with ease at high efficiency levels.

Clientele



Location Plan

North
▼

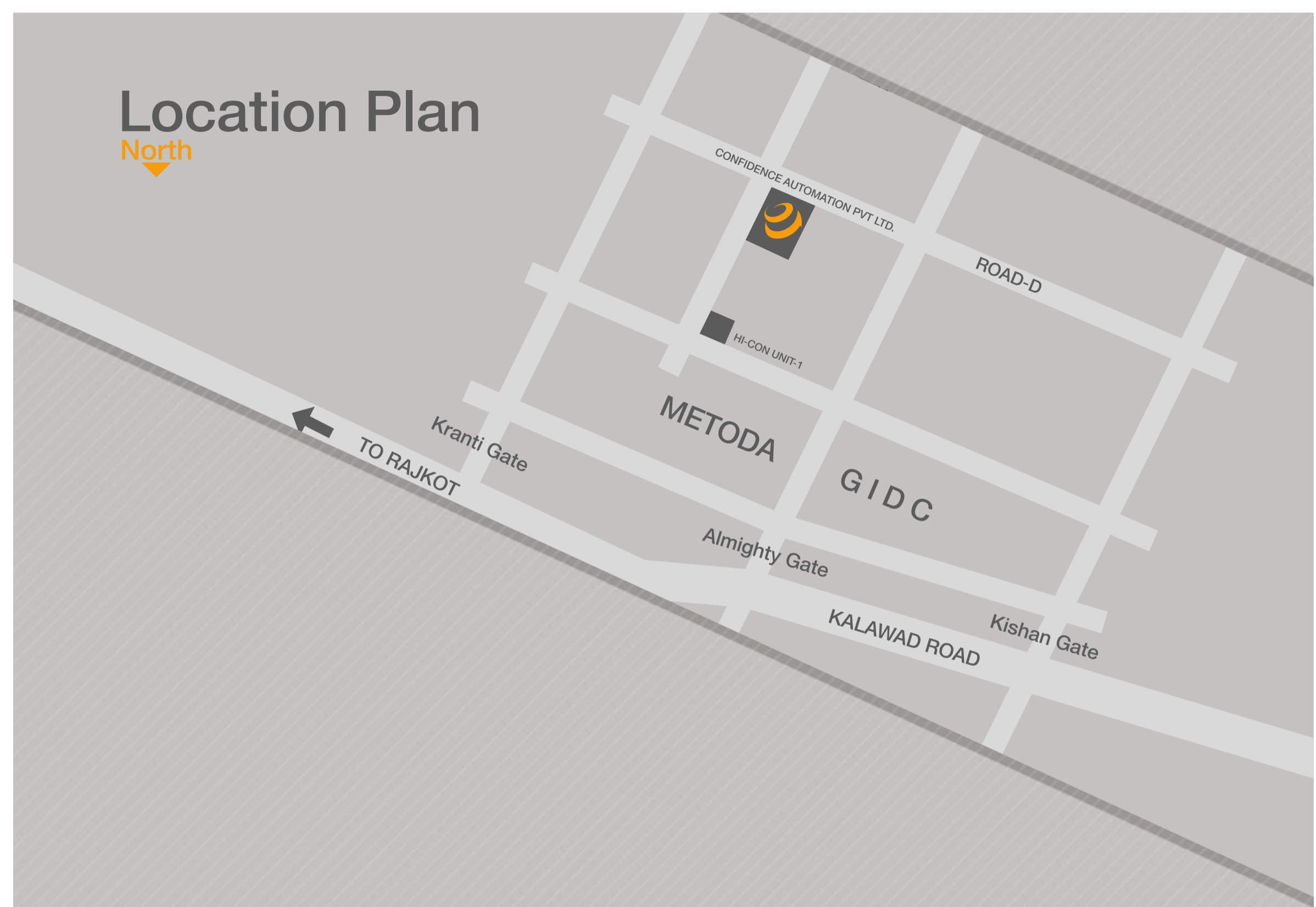

CONFIDENCE
AUTOMATION PVT. LTD.

Plot No. 2301, ROAD-D
Kranti Gate, Metoda GIDC, Ta.Lodhika,
Dis. Rajkot - 360021 (Gujarat) INDIA.
Ph.: 02827 286060 +91 99099 44412, +91 99093 44412

sales@confidenceautomation.com
www.confidenceautomation.com